

Outdoor Unit Multi-zone Heat Pump Ductless System



Heating & Cooling Systems

Outdoor Model: **38MGRQ48E--3**

Submittal Data

Job Data:

Location:

Buyer: Buyer P.O. #:

Carrier #:

Unit Number:

Model Number:

Performance Data Certified By:

Date:



MULTI-ZONE STANDARD FEATURES

Features Outdoor:

- Connect up to 5, multiple style indoor units
 - High Wall
 - Cassette
 - Ducted
 - Floor Console
- Variable Speed (Inverter) Compressor
- Basepan Heater factory installed
- Quiet operation
- Aluminum Blue Hydrophilic pre-coated fins

Cooling operating range -13°~122° F (-25°~50° C)
 Heating operating range -22°~86° F (-30°~30° C)

LIMITED WARRANTY*

- 10 year limited to original purchaser on compressor and parts upon timely registration, otherwise 5 years
- *For residential applications. See warranty for full details.



Preferred
SERIES

Compatibility Table

INDOOR UNIT			OUTDOOR UNIT
			38MGRQ48E--3
High Wall	619PHAQ09XA3		•
	619PHAQ12XA3		•
	619PEQ009BBMA		•
	619PEQ012BBMA		•
	619PEQ018BBMA		•
	619PEQ024BBMA		•
	40MHHQ09---3		•
	40MHHQ12---3		•
	40MHHQ18---3		•
Cassette	619REQ009CBMA	40MBCQ09---3	•
	619REQ012CBMA	40MBCQ12---3	•
	619REQ018CBMA	40MBCQ18---3	•
Ducted	619REQ009DBMA	40MBDQ09---3	•
	619REQ012DBMA	40MBDQ12---3	•
	619REQ018DBMA	40MBDQ18---3	•
	619REQ024DBMA	40MBDQ24---3	•
Floor Console	619REQ009FBMA	40MBFQ09---3	•
	619REQ012FBMA	40MBFQ12---3	•

Specifications

System	Size	48	
	Outdoor Model	38MGRQ48E--3	
	Max Number of Zones	5	
Performance Non-Ducted	Energy Star	YES	
	Cooling System Tons	4.0	
	Cooling Rated Capacity	Btu/h	48,000
	Cooling Cap. Range Min - Max	Btu/h	8560-53160
	SEER	22.4	
	EER	12.5	
	Heating Rated Capacity (47°F)	Btu/h	48,000
	Heating Maximum Capacity (5°F)	Btu/h	36,000
	Heating Cap. Range Min - Max	Btu/h	7210-55820
	HSPF	10.2	
	COP (47°F)	W/W	3.6
COP (5°F)	W/W	1.96	
Performance Combination Ducted and Non-Ducted	Energy Star	NO	
	Cooling System Tons	4	
	Cooling Rated Capacity	Btu/h	48,000
	Cooling Cap. Range Min - Max	Btu/h	8510-52580
	SEER	20	
	EER	11.3	
	Heating Rated Capacity (47°F)	Btu/h	49,000
	Heating Maximum Capacity (5°F)	Btu/h	36,400
	Heating Cap. Range Min - Max	Btu/h	7045-54935
	HSPF	10.15	
	COP (47°F)	W/W	3.5
COP (5°F)	W/W	1.89	
Performance Ducted	Energy Star	NO	
	Cooling System Tons	4.0	
	Cooling Rated Capacity	Btu/h	48,000
	Cooling Cap. Range Min - Max	Btu/h	8460-52000
	SEER	17.6	
	EER	10.1	
	Heating Rated Capacity (47°F)	Btu/h	50,000
	Heating Maximum Capacity (5°F)	Btu/h	36,800
	Heating Cap. Range Min - Max	Btu/h	6880-54050
	HSPF	10.1	
	COP (47°F)	W/W	3.4
COP (5°F)	W/W	1.82	

Operating Range	Cooling Outdoor DB Min - Max	°F(°C)	-13-122 (-25-50)
	Heating Outdoor DB Min - Max	°F(°C)	-22-86 (-30-30)
Piping	Total Piping Length	ft (m)	328(100)
	Piping to furthest FCU	ft (m)	115 (35)
	Drop (OD above ID)	ft (m)	65(20)
	Lift (OD below ID)	ft (m)	65(20)
	Pipe Connection Size - Liquid	in (mm)	1/4*5(6.35*5)
	Pipe Connection Size - Suction	in (mm)	1/2 *2+ 3/8*3 (12.7*2+9.52*3)
Refrigerant	Type	R410A	
	Charge	lbs (kg)	10.13 (4.6)
	Metering Device	EEV	
Electrical	Voltage, Phase, Cycle	V/Ph/Hz	208/230-1-60
	Power Supply	Indoor unit powered from outdoor unit	
	MCA	A.	35
	MOCP - Fuse Rating	A.	50
Compressor	Type	R410A	
	Model	ATQ360D1UMU	
	Oil Type	ESTER OIL VG74	
	Oil Charge	Fl. Oz.	49.38
	Rated Current	RLA	21
Outdoor	Unit Width	in (mm)	41.15 (1045)
	Unit Height	in (mm)	52.48 (1333)
	Unit Depth	in (mm)	17.63 (448)
	Net Weight	lbs (kg)	223.8 (101.5)
	Airflow	CFM	4500
	Sound Pressure	dB(A)	64

Construction View

Outdoor Model: 38MGRQ48E--3

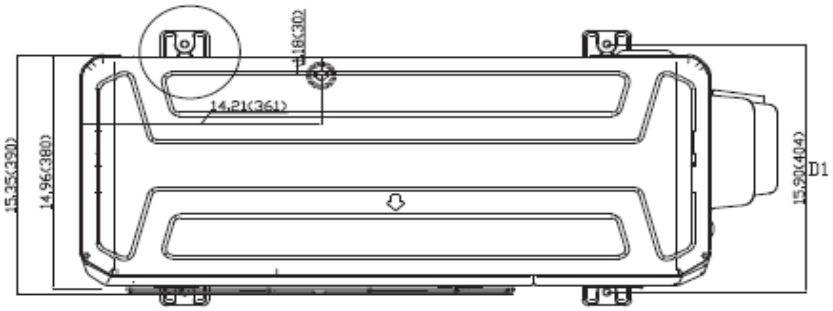
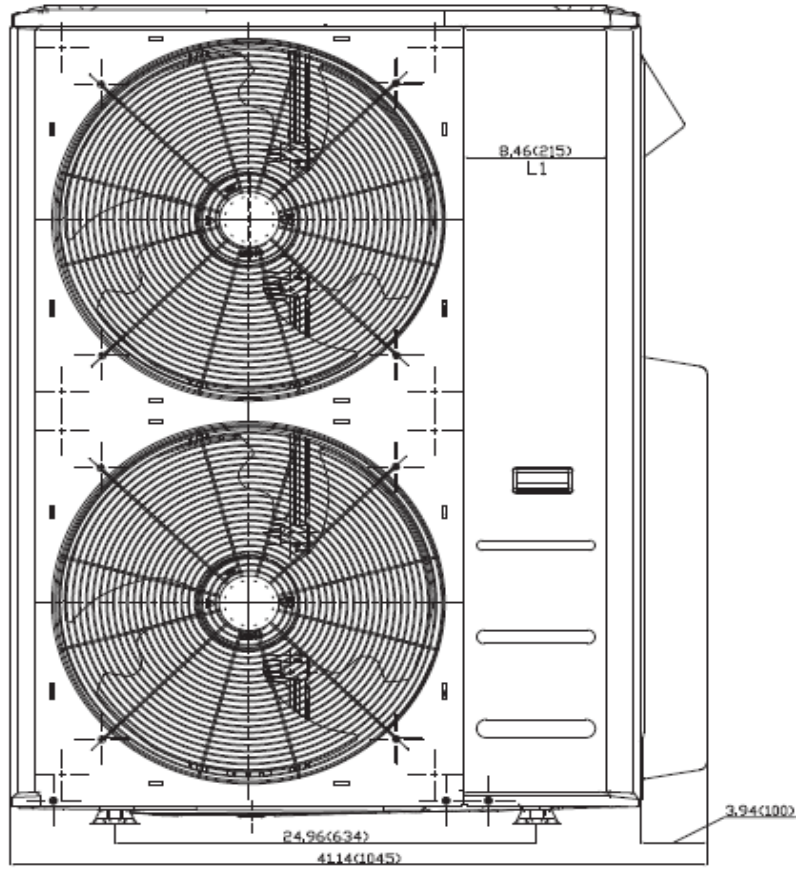
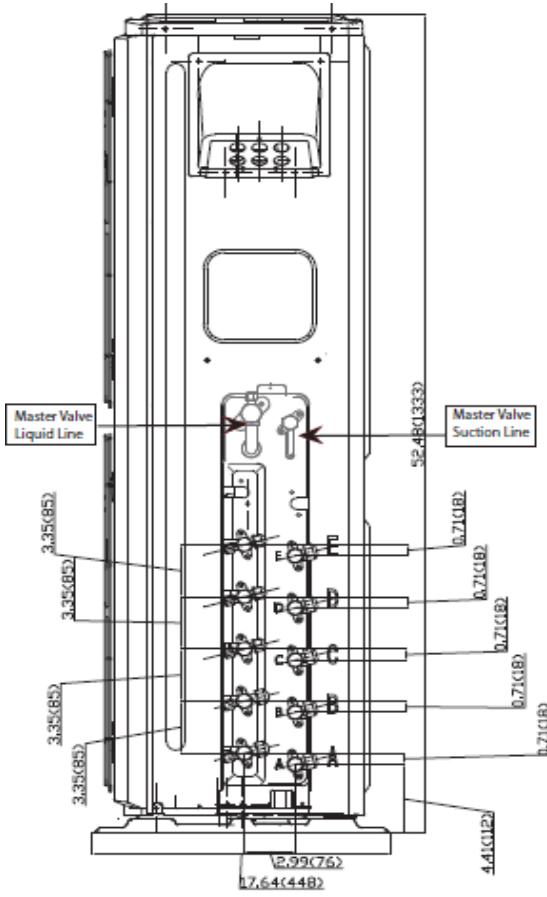

DETAIL .

